

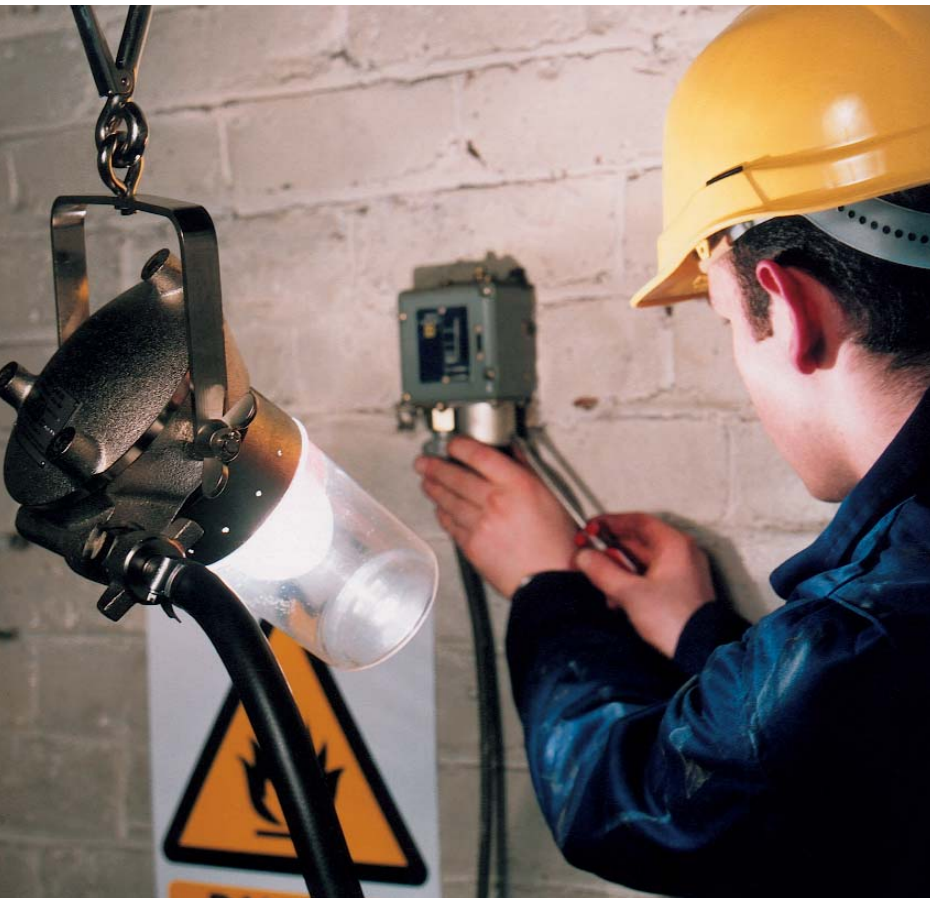

# WOLF TURBOLITE LAMPS



- 250 Watt Halogen Ultimate Output
- Electronic Setting Device
- Generator Overspeed Protector
- Advanced Internal Topology Rotor Design
- Spark Free Brass Casings
- International Market Leaders
- Full Accessory Range Available

#### Wolf Turbolite A-TL44

250w with ball glass for all round illumination  
Peak luminous intensity at 2.5m radius **70lux**

#### Wolf Turbolite A-TL45

250w with polished reflector spot beam (approx 10°)  
Peak luminous intensity at 5m **2000lux**

#### Wolf Turbolite A-TL45

250w with matt reflector flood beam (approx 25°)  
Peak luminous intensity at 5m **950lux**



A-TL44

A-TL45

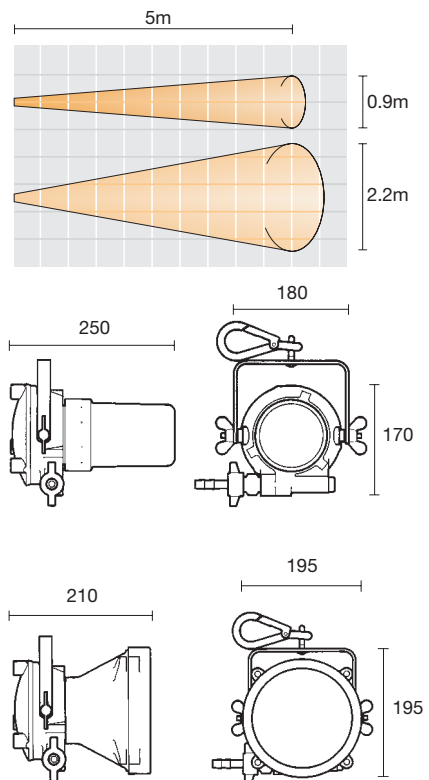

The Turbolite range of compressed air driven lighting was developed as the high power version of the well known Wolf Airturbo. The Turbolite is certified for use in zones 1 and 2 hazardous areas.

Common applications are in the Oil and Petrochemicals Industries, for tank cleaning and pipeline inspections, offering a safer alternative to low voltage lighting in dangerously wet conditions as well as where flammable gases and vapours can accumulate in confined spaces.

**Turbolite Type 44** – has a Bay Light fitting comprising a ball glass and protective polycarbonate dome to provide all-round, general purpose illumination. A hook provides for suspension of the lamp in the working area, or for simple fastening to a folding tripod.

**Turbolite Type 45** – has a reflector head fitting for direct floodlit illumination. Polished or matt reflectors give the option of a concentrated narrow beam or diffused wide angle illumination.

The housings of the Turbolites are cast brass, a spark free material, and the safety hook is also brass, but forged for extra strength. All external parts are nickel plated. Internal components are of durable design making the products suitable for use in the harshest industrial environments.

A clean dry air supply is a condition of certification and essential for the efficient running of these lamps,

otherwise contamination will deposit into the inside of the lens, reducing illumination levels. Suitable air-line filters can be supplied by the Company. Another mandatory requirement is the use of anti-static hose, because in a hazardous atmosphere the smallest static discharge can have disastrous consequences.

The 24 volt 250 watt tungsten halogen bulb is available in two types offering a choice of 6,000 lumens for 2,000 hours or 9,000

lumens for 200 hours. All items of spare parts including bulbs and alternative reflectors are readily available from stock.

Turbolite lamps are run in, tested and set to the necessary output prior to despatch. The lamps are simple and easy to maintain and supplied with full maintenance instructions and spare parts diagrams and lists. In-house training on maintenance, setting and operation of air lamps is available.

<b>Turbolite High-Power Air Powered Safety Lamps</b>		
<b>Technical Specification</b>		
<b>Product reference</b>	<b>A-TL44</b>	<b>A-TL45</b>
<b>Product description</b>	Safety bay light, compressed air powered	Safety flood light, compressed air powered
<b>Code</b>	Ex s II T4	
<b>Apparatus standard</b>	SFA 3009:1972	
<b>Type of protection</b>	"s" special protection	
<b>Area of classification</b>	Zones 1 and 2, gas groups IIA, IIB and IIC	
<b>Temp. classification</b>	T4	
<b>Ambient temperature</b>	-20°C to +40°C	
<b>Certification</b>	BASEEFA Certificate No. Ex 78209X*	
<b>Enclosure</b>	Nickel plated brass and gun-metal	
<b>Lens</b>	Ball glass/plastic dome	Toughened glass (15mm)
<b>Beam type</b>	All-around 360° illumination	Flood (as standard) or spot to order
<b>Light source:</b>	Pt. no.	<b>A-129</b> (as standard)/ <b>A-159</b> (alternative)
	Type	Tungsten halogen filament bulb
	Volts	24v
	Watts	250w
	Output	6000 lm/9000 lm
	Life	2000 hrs/200 hrs
<b>Power source:</b>	Type	Compressed air driven turbo-alternator
	Air pressure	4.0-8.0 bar
	Consumption	0.75m <sup>3</sup> /min
<b>Ingress protection</b>	Once pressurised, may be used underwater	
<b>Weight</b>	7.9kg	12.2kg
<b>*Special certification conditions</b>	A clean dry air supply must be used. Supply hose must be anti-static.	

Note: All information has been gathered under laboratory conditions, the user must regard the values given as approximate. The Company reserves the right to alter product specifications without prior notice.

## **WOLF SAFETY LAMP COMPANY**

**Saxon Road Works, Sheffield S8 0YA, England**

**Tel: +44 114 255 1051 Fax: +44 114 255 7988**

**E-mail: info@wolf-safety.co.uk Website: www.wolf-safety.co.uk**

MMD/N/12.03/2K



**Wolf Safety Lamp Company**